



SECURECASH  
MK II



➤ Remote control

➤ Maximum security

➤ Easy to use

# SECURECASH

MK I

## THE USE OF SECURECASH IS A SUBSTANTIAL IMPROVEMENT IN THE MANAGEMENT OF BANKNOTES AND COINS

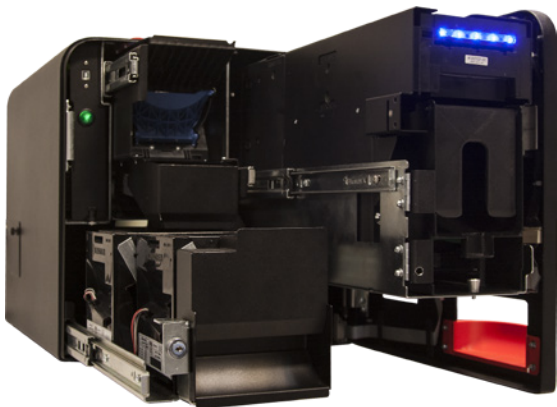

Securecash payment tower solution provides optimized cash management to any POS, improving the control of any business (gas stations, supermarkets, call centers, large surfaces, restaurants, bars, fast-food, ...), and providing full safety to prevent internal fraud and deter potential robbers.

Securecash allows the following functions to be performed automatically:



### MAIN FUNCTIONS

Automatic cash management in the point of sale.

Identification of the employees by access code or fingerprint.

Counting and validating the customer payment (bills and coins).

Return of the exact change (bills and coins).

Facilitate the cashiers shifts and the accountancy closing since the cash count and cash float preparation are automatic.

Local or remote control of the accounting and operational status of Securecash units, allows the optimization of cash availability in each of them.

Prevent internal fraud: employees do not have access to the stored cash.

Safe system that dissuades potential robbers.

Hygienic environment that facilitates the execution of the payment by the client.

### SIZE AND ERGONOMICS

Its small size and ergonomics allows an easy installation in any location, giving an image of modernity, which will contribute to growth and customer fidelity.

The Securecash solutions are offered in two main configurations:

Securecash MK I and Securecash MK II

### EMPLOYEE PRODUCTIVITY

The Securecash also allows to improve the employees productivity.

Being freed from the tasks of counting, validating and tidying the storage of banknotes and coins, the employee can provide better customer service and even promote products and services that may interest them.

The automatic accounting closing allows a usable time on other tasks.



## COIN RECYCLER

Accepts all denominations including 1 eurocent.

Accepts and validates coins in bulk (up to 100).

Validates 3 to 4 coins / second.

Rejects of non- genuine coins.

Recycles up to 8 denominations.

High speed dispensing.

Hoppers multi-coins can handle up to 4 denominations/ hopper, capacity 325 to 775 (referred to 2 € and 5 cent).

Secure and removable coins deposit box, capacity 1500 coins (non-recyclables, maximum capacity per coin and hopper overflow).

Automatic audit loading.

Orderly unloading of hoppers to output mouth.



## SECURITY OPTIONS

3 mm steel safe for Securecash MK I.

Optional 12 mm steel or CEN IV safes.

Mechanical and electronic key locks of various types according to customer needs.



## DIMENSIONS & SERVICE AREA

Height	418 mm
Width	420 mm
Depth	491 mm



## BANKNOTE RECYCLER

Single mouth banknote reading.

Accepts all denominations.

Accepts and validates notes one by one.

Banknotes do not require prior preparation, accepts any order, any face.

Speed 1,5 to 2 notes / second.

Rejection of non-genuine banknotes.

Recycling up to 3 denominations in independent cylinders with capacity of 50 notes each.

Dispensing of change (3 denominations ).

Removable safety stacking cassette to store non recyclable denominations or excess of recycled ones (500 notes).

Orderly loading of cylinders from mouth.

Orderly unloading of cylinders to mouth or to safety

Transportable stacking cassette.

\*MK II with integrated TPV

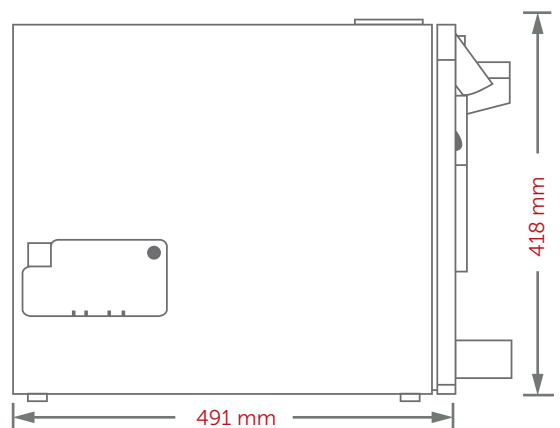
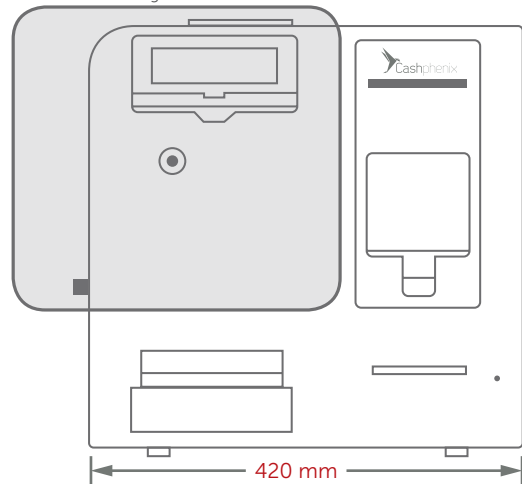

Compact cabinet for easy installation over counter.



## EMPLOYEE IDENTIFICATION & USER INTERFACE (OPTIONS)

LCD of 4 lines with 20 characters each.

# SECURECASH

MK II

THE MK II SYSTEM IS A NEW VISION OF THE TRADITIONAL INTELLIGENT DRAWER  
MK I ADDS INTEGRATED POS, POS READY AND GREATER CONNECTIVITY



## MORE FUNCTIONS AND BENEFITS

The MK II system shares all the main functions of its brother the MK I, as well as its Recycling features of coins and bills, security and dimensions of the cabinet.

The MK II maintains and increases the current benefits of predecessor, the MK I, as to connectivity, integration of devices and POS.



### POS READY

POS READY option allows you to integrate the different point of sale devices in a complete and compact solution.



### EASY CONNECTION

Securecash MK II provides ease connection for different devices at the point of sale, eliminating the problem of cables that have to be hidden and protected so that they do not cause problems in the normal operation of our business.



### VESA STAND

It incorporates Vesa support for POS assembly, installed on the front of the equipment to be handled by our employee, or in the back of the same then clients enter directly the money in the machine, thus allowing to comply with the standards of food handling and hygiene of your business.



### INTEGRATED CONNECTIONS

Switch and device connection hub (Ethernet, USB), complete the POS READY solution offering to our customers an advanced, compact system and innovative automatic cash management and point of sale.

# SECURECASH

## DEPOSIT

### SECURECASH DEPOSIT COMBINES THE INTELLIGENT POS FUNCTION AND CASH DEPOSIT AT THE FRONT OFFICE.

This implies to have a **closed and safe cycle**, eliminating the risks derived from handling the collected cash at the point of sale.



Securcash deposit solution allows cash management to be improved by the cashier, completing collection and payment operations with return of change and providing total security by avoiding internal fraud and dissuading potential robbers.

In addition, the excess of cash required as a cash fund for changes can be automatically deposited in the security box inside the deposit bags for transportation, which allows compliance with the citizen security norm in sectors such as: gas stations or service stations, large shopping centers, 24-hour shops, recreational parks and leisure areas.

With Securcash deposit, having a safety box approved by the transport companies of funds, you can choose to hire convenient products as "date value"(once the money is in the safe, it will appear in your account) for the cash that is deposited in the safe, or simply withdrawal of funds, which from now on will be reduced since it will be able to lodge more cash during more time.



## MAIN FUNCTIONS

The Securcash Deposit unit shares all the main functions of its brothers; MK I and MK II, as well as its characteristics of coin and bank recycler, connectivity, device integration and POS.

### MORE FUNCTIONS AND BENEFITS

- Automatic storage of the collection within the security vault.
- The amount that you want to keep as a cash fund is programmable.
- It allows to store more amount of cash when it is deposited in the security box, minimizing the risk of transferring the daily collection to the Bank.
- Facilitates the cash withdrawal by the fund transport company with security transport bags.





MAIN CHARACTERISTICS		MK I	MK II	DEPOSIT MK I	DEPOSIT MK II
<b>User display</b>					
LCD	4 lines of 20 characters/line				Optional
Screen	15" Led back-ligh, True-Flat. Capacitive touch	✓	✓	✓	
<b>Banknote recycler</b>					
Speed	Accepts / Dispenses: 1,5 to 2 banknote/sec	✓	✓	✓	✓
In / Out	1 / 1				
Banknote entry	One by one				
Accepts / Validates	All denominations (5 to 500 €, configurable)				
Dispenses	3 denominations				
Uds. de reciclaje	3 cassettes				
Capacity	50 bill./cylinder. Total 150 bills				
Removable safety stacking cassette (stacker)	500 stacked banknotes				
Deposit Bag	Capacity for 2.000 or 5.000 banknotes				
Counterfeit notes rejection	Yes (Certified as per European standard))				
Bundle acceptance	Up to 50 banknotes	Optional	Optional	Optional	Optional
<b>Coins recycler</b>					
Acceptance / Dispensing speed	Accepts 3 to 4 coins/sec. Dispenses up to 10 coins / sec.	✓	✓	✓	✓
In / Out	Up to 100 coins /Up to 250 coins				
Accepts / Validates	All coins (1 cent to 2 €)				
Dispenses	Up to 8 denominations				
Recycling units	2 multi-coins hoppers				
Capacity/hopper	325 coins (2 €) to 775 coins (5 cents)				
Deposit box (overflow)	1.500 coins capacity	✗	✗	✓	✓
Counterfeit coins rejection	Yes (Certified as per European standard)				
<b>Processing unit</b>					
CPU with RS232 connection to POS		✓	✓	✓	✓
POS (Intel Celeron, 2 GB RAM upgradable. Solid Hd 64 GB, Win 10 Pro, Ethernet)		✗	✓	✗	Optional
<b>Card payment</b>					
By means of POS card reader devices		✓	✓	✗	
Insertion type card reader + Pin-Pad + RFID reader		✗	✗	✗	✗
<b>POS Ready</b>					
VESA stand to install any POS		✗	✓	✗	✓
Internal Ethernet and USB connections for POS connected devices and cabling clean environment (printers, finger print reader, Barcode scanner, ...)		✗	✓	✗	✓
<b>Security cabinet</b>					
Ground anchoring				✓	✓
Key protection for any Access to banknotes or coins				✓	✓
Transportable bags for banknote and coin deposit				✓	✓
Closing Security system for cash bags with security lid and seal for transport				✓	✓
2 safety locks for the bag extraction: the first is released by inserting a lid with security lock and the second, once the bag is closed a dynamic code is required for the total extraction				✓	✓
3 mm steel thickness, anchoring, cash access protection by keys		✓	✓	✗	✗
Options: 5mm box, UL291 or CENIV box with electronic combination lock including delayed opening, seismic alarm and connection to alarm center		✗	✗	Optional	Optional
<b>Software</b>					
Securecash managment and integration module with POS applications software		✓	✓	✓	✓
<b>Remote control application</b>					
	Securecash operative and accountancy state control	Optional	Optional	Optional	Optional
	Sales by periods, users, different cash points				
	Consultancy for most commonly used bills and coins in acceptance and in exchange				
	Diagnostic and monitoring				
	Alarms for customer and technical service				
	Remote configuration				
<b>Connectivity</b>					
		RS232-USB	Ethernet, RS232-USB, USB	2xRS232 o RS232-USB	2xEthernet, 2xRS232 o 2xRS232-USB, 2xUSB
Dimensions (mm) and weight (kg) The most compact solution in the market	Width	420	420	430	430
	Depth	491	491	491	491
	Height	418	418	1.310	1.310
	Weight	55	55	180	180
	Height of the safe			812	812

## LITHUANIA

Darkiemo str. 22,  
Vilnius LT-06230  
+370 620 211 48  
sales@cashphenix.com

## SPAIN

Avda. del Camino de lo Cortao 34, Nave 7,  
28703 San Sebastián de los Reyes, Madrid  
+34 916 59 22 00  
sales@cashphenix.com

## USA

724 SW 4th Street,  
Hallandale Beach, FL 33009  
+1 (954) 235 0648  
sales@cashphenix.com